

G.MILANI S.A.S.

DI TETTONI FABRIZIO & C.

VIA CAVAGLIETTO, 25

28010 - CAVAGLIO D'AGOGNA NO (ITALIA)

P.IVA: 02626650036

SDI: W7YVJK9

MAIL: INFO@GMILANI.IT

PEC: G.MILANISAS@PEC.IT

TEL: +39.0322.80.68.20

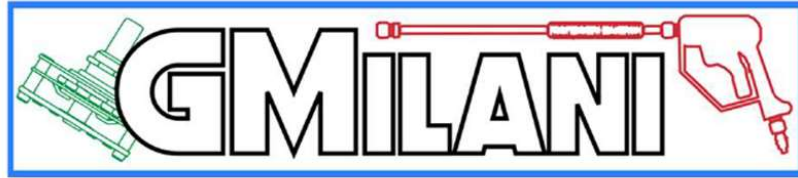

EQUIPMENT FOR COLD WATER PRESSURE WASHERS TLR 20

Features:

Power supply:

230/400 Vac – 50/60 Hz

Supported motor loads:

400 V up to 20 kW – 27 HP

230 V up to 8 kW – 10.8 HP

Control:

microprocessor-based control

Auxiliary output 24 Vac:

max 100 mA, function configurable via software

Control inputs:

low voltage pressure switches

Low voltage input:

for general On-Off control

Electrical connections:

6 mm² cables for power, 0.5 mm² for controls, with Mammut-type connectors

Mechanical characteristics:

Dimensions (L × D × H): 100 × 100 × 48 mm, Weight: 950 g

Pump motor output:

internally controlled by 3 relays rated 90 A each, with varistor on each relay for reduction of overvoltages and contact arcing

Protection:

Electronic board encapsulated in epoxy resin against dust and humidity

Description:

The new TLR20 has been specifically designed for the management and control of cold water pressure washers, expanding the range of supported power within the TLR family. This version is specifically equipped with power and control cables to allow optimal use of the relay current, not achievable with the Faston connections used on the TLR15.

The board operates as a timer for pump motor control, with a standard timing set to 15 seconds (adjustable via software).

The TLR20 is fully microprocessor-controlled and can be configured directly by the operator via the TesterTLR software, usable on Windows PC.

Each unit is serialized (serial number visible via software), ensuring full traceability of each device. It is possible to configure timings, enable or disable specific functions, and monitor various hour counters, both total and partial.

24 Vac configurable output

The board is equipped with a 24 Vac output (max 100 mA), whose function can be selected via software between two modes:

- External hour counter: activated in parallel with the pump, typically used to control an external hour meter (available on request).
- Indicator light: provides specific alerts through flashing signals, depending on number and sequence settings.

Maintenance management

The TLR20 includes an internal hour counter, visible via software, allowing advanced machine maintenance management.

A partial hour counter is available for maintenance alerts: when the set threshold is reached, the need for routine maintenance is signaled. Reset can only be performed via software.

It is also possible to define the board behavior when the threshold is reached:

- continue normal operation;
- completely stop the machine after exceeding a second configurable threshold.

All functions can be configured and disabled via the TesterTLR software.



MADE IN ITALY

G.MILANI S.A.S.
DI TETTONI FABRIZIO & C.
Via CAVAGLIETTO, 25
28010 - CAVAGLIO D'AGOGNA NO (ITALIA)

P.IVA: 02626650036
SDI: W7YVJK9
MAIL: INFO@GMILANI.IT
PEC: G.MILANISAS@PEC.IT
TEL: +39.0322.80.68.20

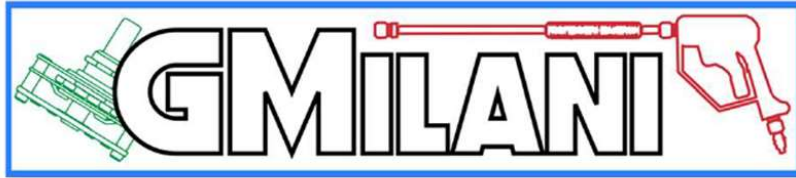

ALARM INDICATION DESCRIPTION WITH ACTIVE WARNING LIGHT FUNCTION TLR 20

STEADY LIGHT – Total lock due to missed maintenance
(reset by authorized service network)

1 FLASH – Recommended routine maintenance alert
(reset by authorized service network)

2 FLASHES – Lock: pump always on
(turn off power for a few seconds to restore operation)

3 FLASHES – Micro-leaks / false starts
(turn off power for a few seconds to restore operation)

4 FLASHES – Lock due to inactivity
(turn off power for a few seconds to restore operation)

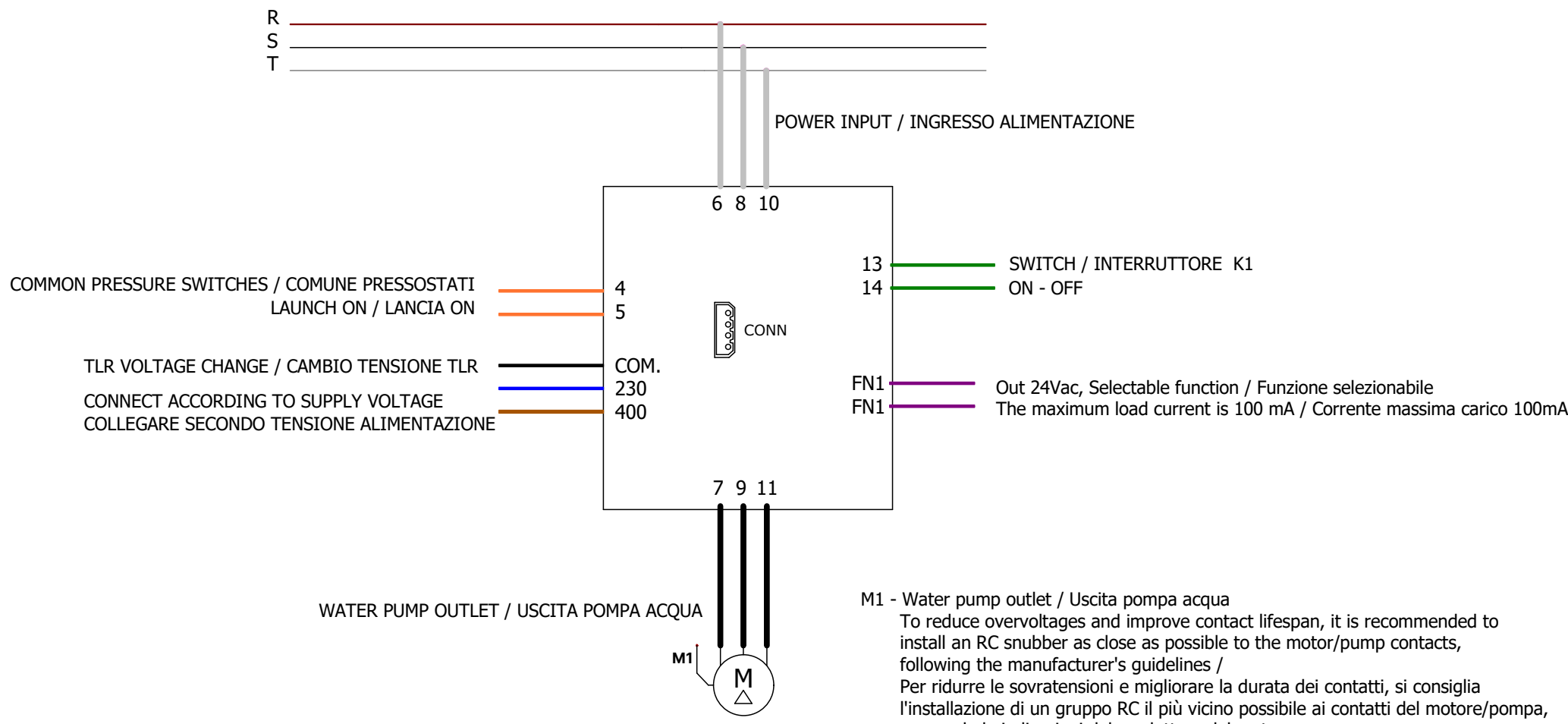

M1 - Water pump outlet / Uscita pompa acqua
To reduce overvoltages and improve contact lifespan, it is recommended to install an RC snubber as close as possible to the motor/pump contacts, following the manufacturer's guidelines / Per ridurre le sovratensioni e migliorare la durata dei contatti, si consiglia l'installazione di un gruppo RC il più vicino possibile ai contatti del motore/pompa, seguendo le indicazioni del produttore del motore.

K1 - Low Voltage Switch / Interruttore Bassa Tensione

FN1 - 24VAC output, configurable via software:
For external hour meter / Per contaore esterno
As a warning indicator / Per spia segnalazione

CONN - Connector interface with PC / Connettore interfaccia PC
In single phase do not use 10-11 / In monofase non usare 10-11

TLR20 Cavi

CONTRACT:

REV.	DATE
DESIGNED	G.Milani

G.MILANI S.a.s
DI TETTONI FABRIZIO & C.
 VIA CAVAGLIETTO, 25
 28010 - CAVAGLIO d'AGOGNA NO (ITALIA)
 mail: INFO@GMILANI.IT
 tel: +39.0322.80.68.20

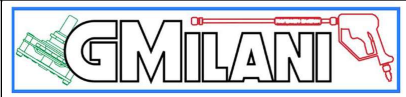

SCHEME

- P1 - Pressure switch generally mounted on the pump / Pressostato generalmente montato su Pompa
- P2 - Pressure switch generally mounted on Bypass valve / Pressostato generalmente montato su Valvola Bypass
- CONN - Programming interface connector with PC via TesterTlr software / Connettore interfaccia programmazione tramite software TesterTlr

Example of a connection with main switch, fuse, and motor circuit breaker with 400Vac power supply
 Esempio di collegamento con interruttore generale, fusibile e termica motore con alimentazione a 400Vac

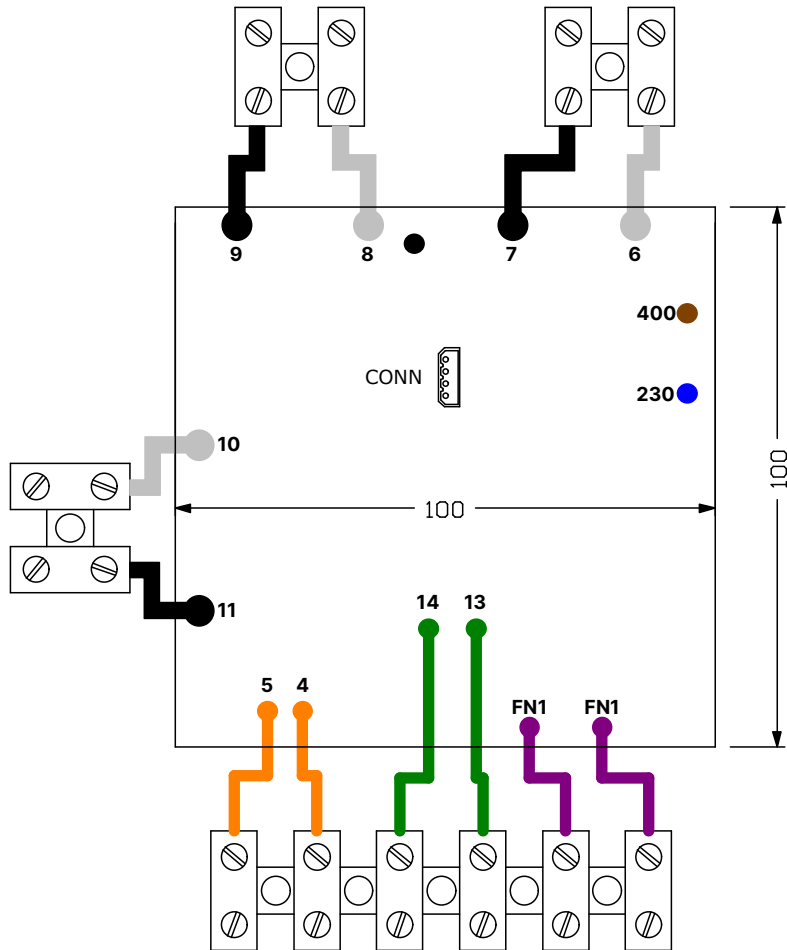

Example of pressure switch connection
 Esempio collegamento pressostati

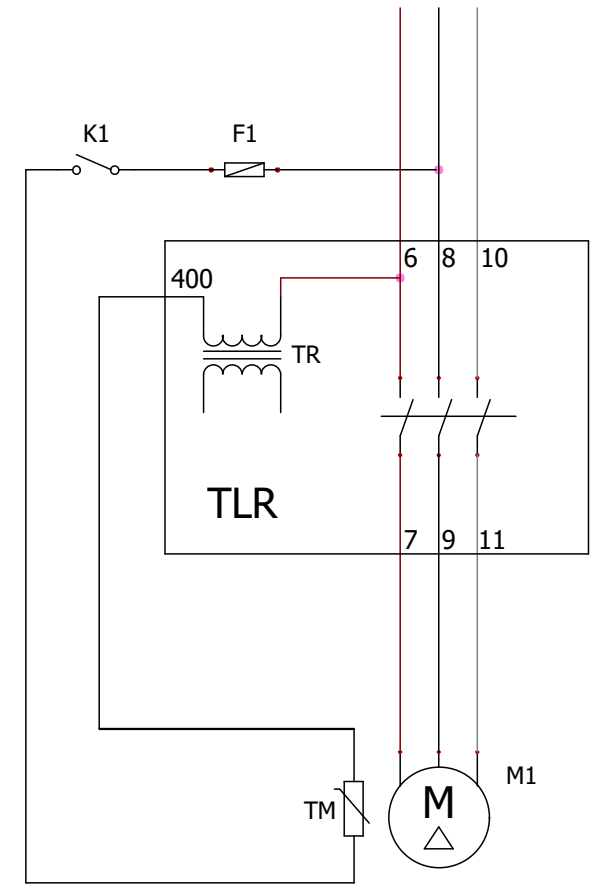
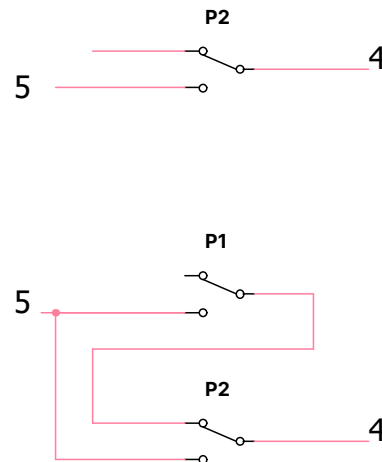

- M1 - Motor pump / Motore pompa
- TR - Internal TLR power supply / Alimentazione interna
- F1 - Fuse / Fusibile
- K1 - Main switch / Interruttore generale
- TM - Motor safety thermal switch / Interruttore termica sicurezza motore

TLR 20 CAVI

REV. DATE

DESIGNED
G.Milani

G.MILANI S.a.s
DI TETTONI FABRIZIO & C.
 VIA CAVAGLIETTO, 25
 28010 - CAVAGLIO d'AGOGNA NO (ITALIA)
 mail: INFO@GMILANI.IT
 tel: +39.0322.80.68.20

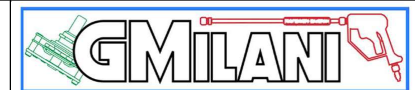

SCHEME

CONTRACT: